

THE INFORMATION CONTAINED HEREON IS THE PROPERTY OF PENTAIR WATER, INC. NO PORTION OF THIS DATA SHALL BE RELEASED, DISCLOSED, USED, OR DUPLICATED FOR USE IN PROCUREMENT OR MANUFACTURING WITHOUT SPECIFIC WRITTEN PERMISSION FROM PENTAIR WATER, INC.

COMPUTER GENERATED DOCUMENT.
MANUAL CHANGES NOT ALLOWED.

REVISIONS					
PCO	REV	DESCRIPTION	DRAWN BY	DATE	CHKD BY
	A.00	INITIAL DRAFT	PA	7/9/14	

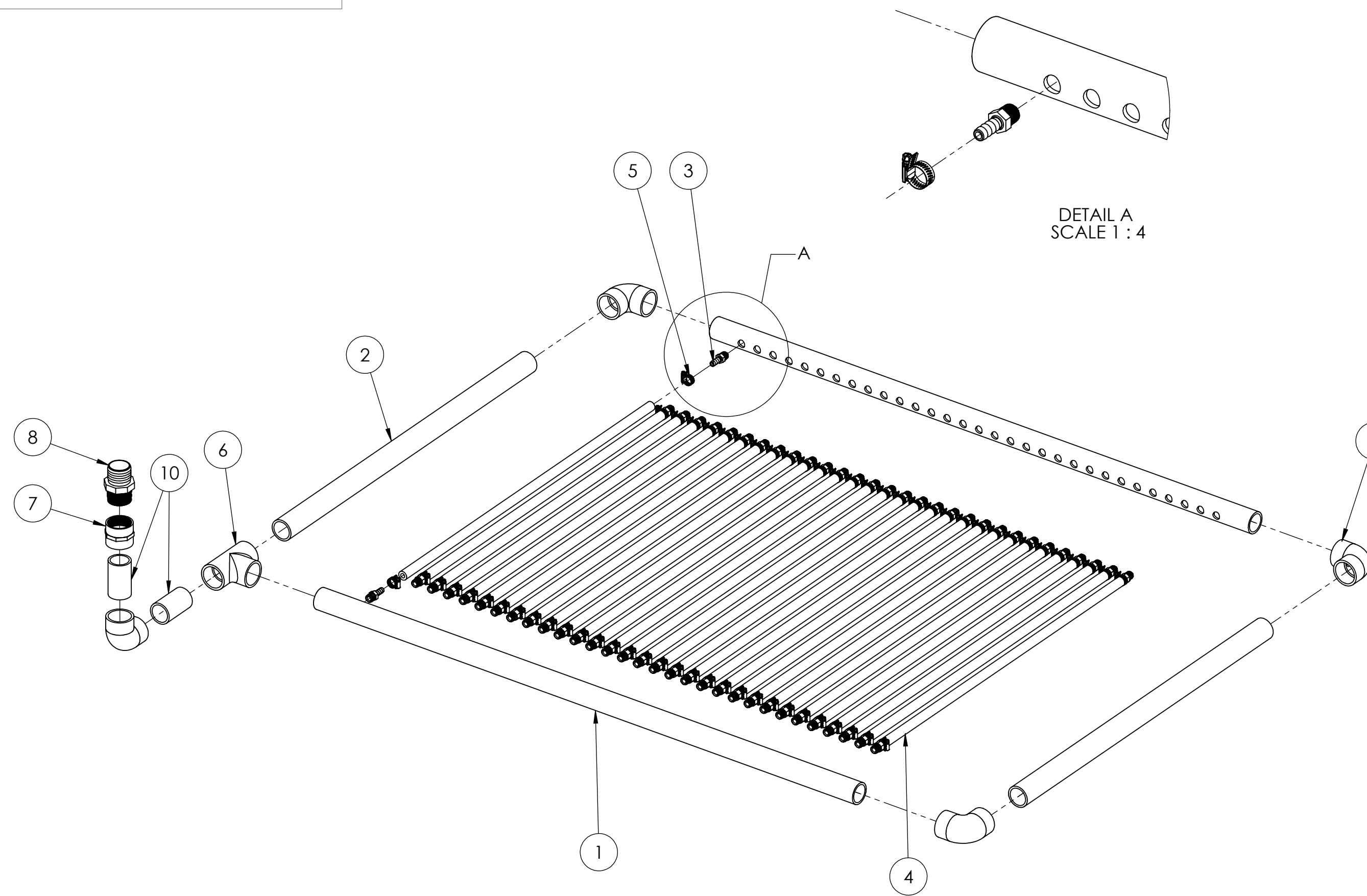
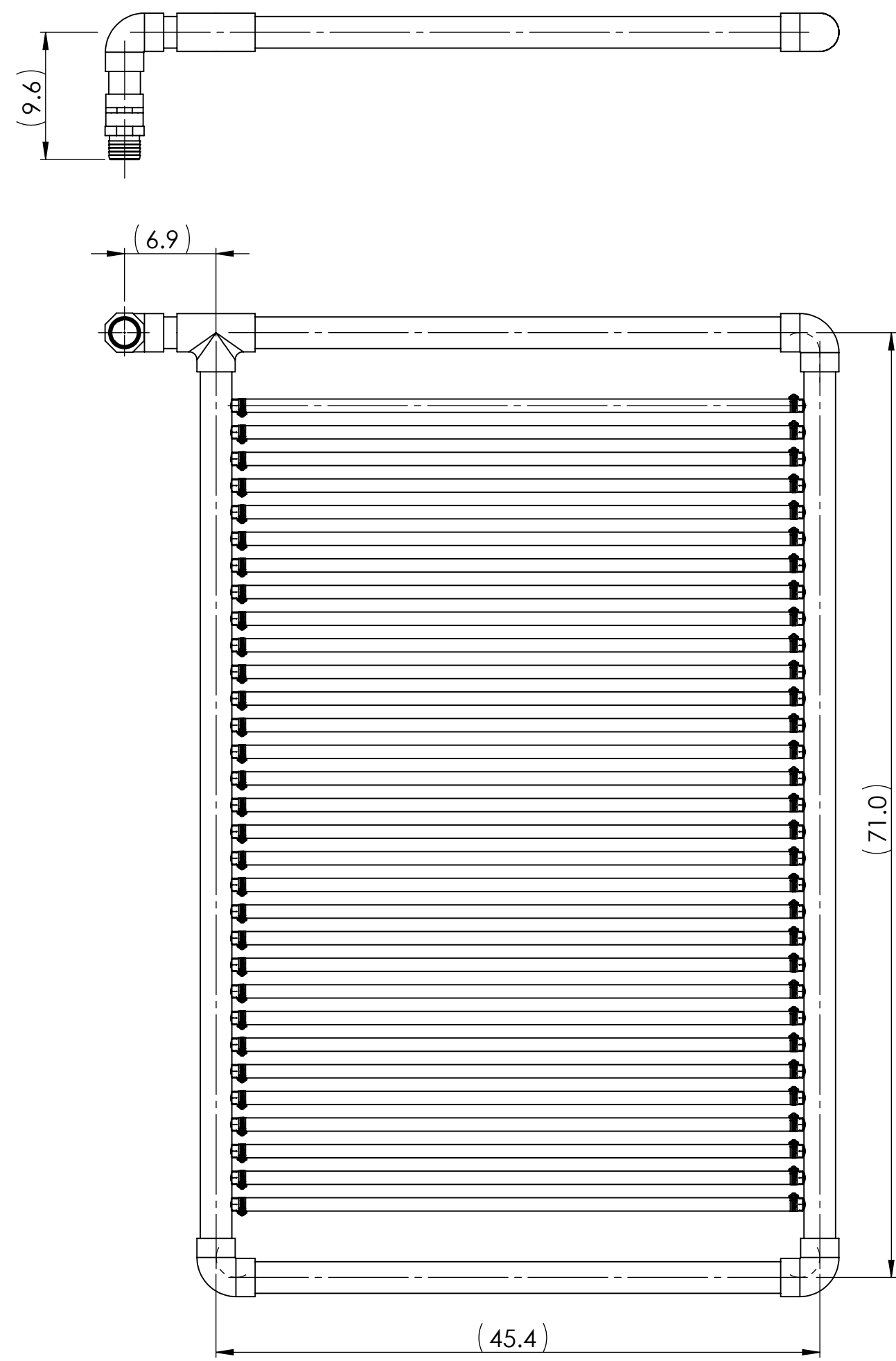

DETAIL A
SCALE 1 : 4

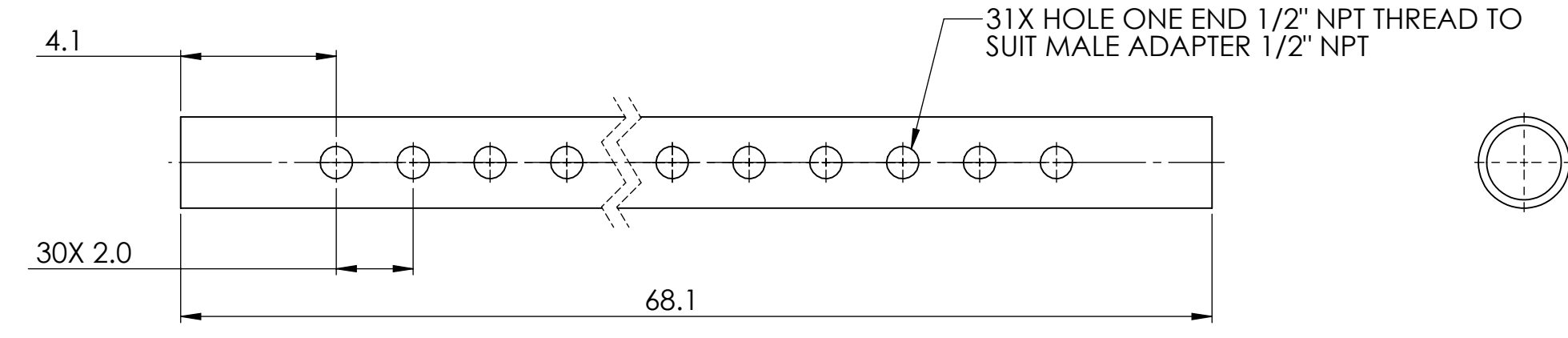
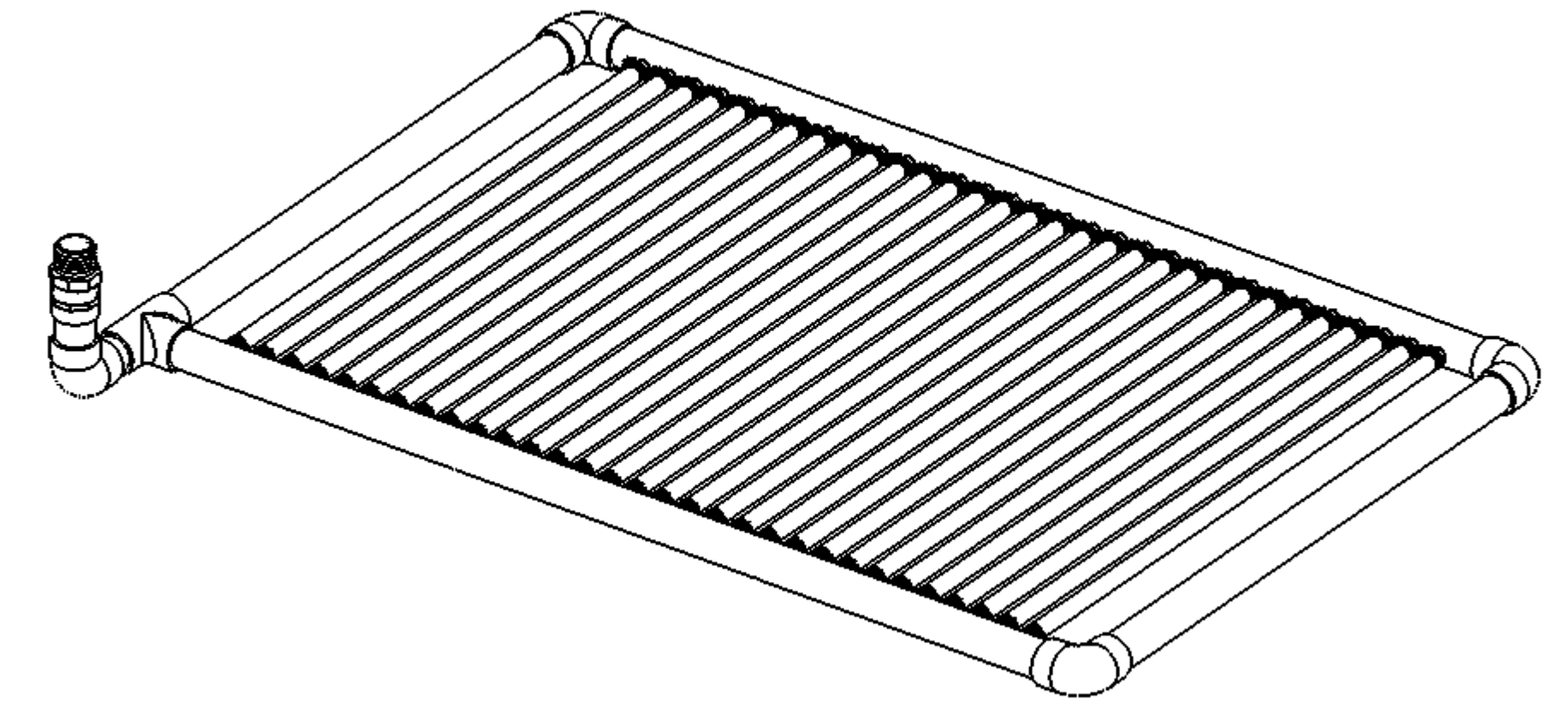

ITEM NO.-1
PIPE 2" PVC SCH80
SCALE 1 : 4

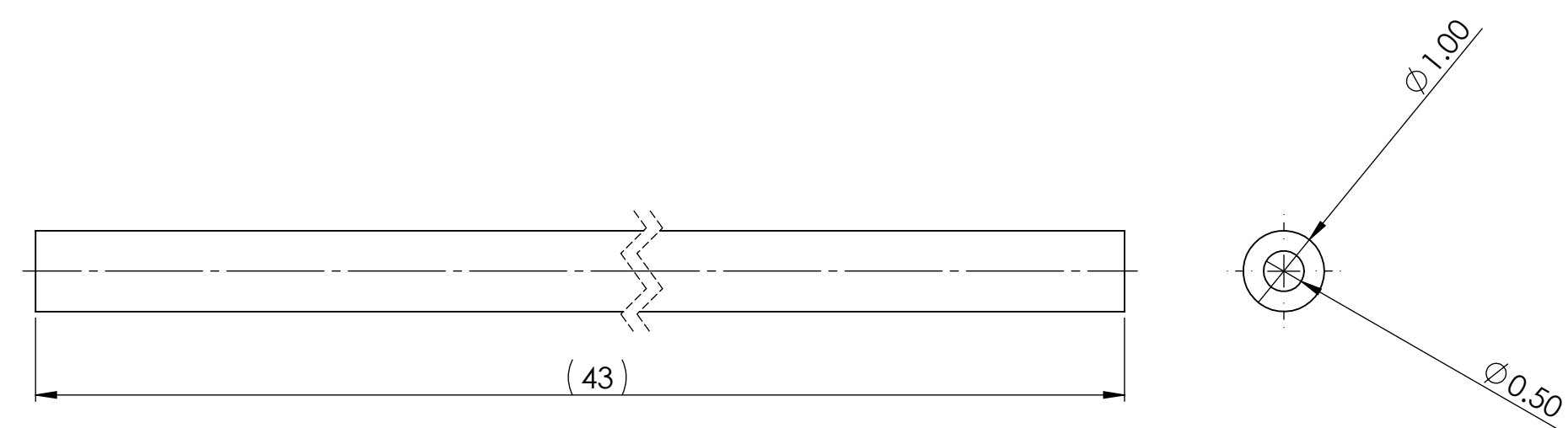

ITEM NO.-4
DIFFUSER TUBE-PERFORATED
SCALE 1 : 2

PIPING AND DIFFUSER TUBING SUMMARY

ITEM DESCRIPTION	LENGTH(FT)
PIPE 2" PVC SCH80	20
DIFFUSER TUBE -PERFORATED	115

2. SUGGESTED VENDOR FOR ITEM 4: Swan, 1201 Delaware Ave, Marion, OH 43302
Toll Free: 1-800-848-8707
www.coloriteaerationtubing.com

1. SECURE DIFFUSER TUBE (ITEM NO.- 4) WITH HOSE CLAMPS (ITEM NO.- 5) ON ADAPTERS (ITEM NO.- 3) TO AFFORD MINIMAL SAG IN THE TUBING

NOTES: UNLESS OTHERWISE SPECIFIED

ITEM NO.	QTY.	PART NUMBER	DESCRIPTION
12	1	TEFLON TAPE	TEFLON TAPE
11	1	PVC GLUE	PVC GLUE
10	2	PIPE 2in PVC SCH 80	PIPE 2" PVC SCH80 - 4" LENGTH
9	4	ELBOW-90 DEG 2in PVC SCH80	ELBOW 90° 2" SOC PVC SCH80
8	1	ADAPTER SCH80 2in BARB	ADAPTER 2" MNPT x 2" BARB PVC SCH80
7	1	PVC COUPLING SOCKET_2in	ADAPTER 2" SOC x SR Fip1, PVC SCH80
6	1	TEE 2in PVC SCH 80	TEE 2" PVC SCH80
5	62	HOSE CLAMP	WORM DRIVE HOSE CLAMP SS316, BW 5/16", RANGE 1- 1 1/2"
4	31	DIFFUSER TUBE-PERFORATED	DIFFUSER TUBE-PERFORATED, OD-1", ID-1/2", LENGTH ~43"
3	62	ADAPTER HDPE 0.5in BARB	ADAPTER 1/2" MNPT x 1/2" BARB HDPE SCH80
2	2	PIPE 2in PVC SCH 80	PIPE 2" PVC SCH80 - 42.5" LENGTH
1	2	PIPE 2in PVC SCH 80	PIPE 2" PVC SCH80 - 68.1" LENGTH

UNLESS OTHERWISE SPECIFIED: DO NOT SCALE DRAWING

DIMENSIONS ARE IN INCHES
TOLERANCES:
.X OR X/X = ±1/64"
.XX = ±.01"
.XXX = ±.005"
ANGULARITY: ±1°
REMOVE ALL BURRS & BREAK SHARP EDGES .010" MAXIMUM EXCEPT P/A & SHUT OFFS
DIAMETERS TO BE CONCENTRIC WITHIN .005" T.I.R.

THIRD ANGLE PROJECTION

SIGNATURES: P AJMERA
DATE: 7/9/14
CHECKED: XXXXXXXX
DATE: xxxxxx

SEE PCO FOR APPROVAL SIGNATURES

COMMENTS:

PENTAIR
2395 Apopka Blvd.
Apopka, FL 32703

AQUATIC ECO-SYSTEMS™
TITLE: AIR DIFFUSER FRAME ASSEMBLY-2m

SIZE: DWG. NO. D XXXXXXXX
SCALE: 1:10 WEIGHT:

REV. A.00
SHEET: 1 OF 1